

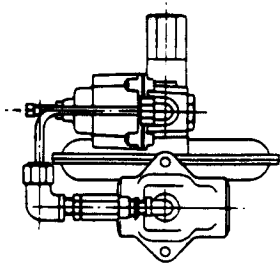

Constant Loaded Regulators

BULLETIN
CL-31N
CL-231N



Actual Piping
Detail CL-31N

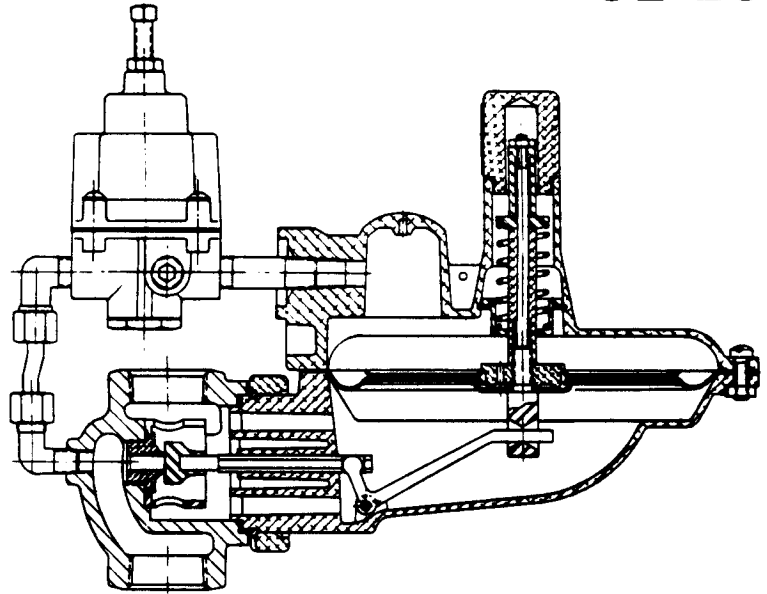

CL-31N Small-Volume Constant Loaded Regulator

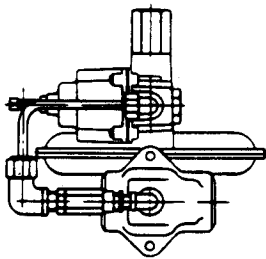

Actual Piping
Detail CL-231N

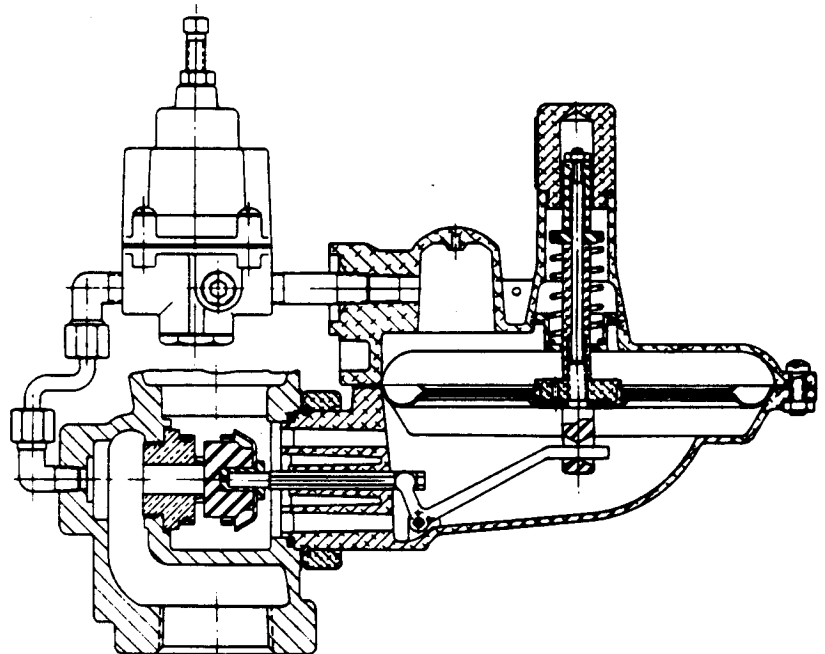

CL-231N Intermediate Volume Constant Loaded Regulator

- Constant pressure loading
- Internal bleed
- Internal lower diaphragm chamber pressure flow control
- Light closing spring
- One adjustable outlet pressure spring
- Built-in screen in pilot

Constant Loaded Regulators CL-31N & CL-231N

General Description

The CL-31N & CL-231N are designed to function the same as the CL-34 Series regulators, and are used where close, straight line, psig to psig regulation is required on flows up to 4000 scfh* (CL-31N) and up to 7500 scfh* (CL-231N).

The main differences between the CL-34 and the above regulators are as follows:

CL-31N has a smaller diaphragm case in the main regulator; a smaller pilot regulator; a series of smaller valve bodies than the CL-34; no adjustable loading ring.

CL-231N has the same smaller diaphragm case and smaller pilot as CL-31N. It also features an adjustable loading ring like CL-34, but with a different setting. (See specifications below.)

Like the larger CL-34 models, the CL-31N & CL-231N incorporate the following advantages which, for many applications, make them most economical substitutes for pilot loaded regulators.

- Constant pressure loading
- Internal bleed
- Internal lower diaphragm chamber pressure flow control
- Light closing spring
- One adjustable outlet spring
- Built-in screen in pilot regulator

Applications

Designed primarily for systems requiring highly accurate pressure regulation, these regulators can produce substantial savings for users in (a) lower initial costs (b) lower installation costs and (c) lower maintenance costs in the following applications:

CL-31N: For small size commercial and industrial applications.

1. Metering relatively small loads (approximately 300 to 4000 CFH)* without expensive instrumentation.
2. As a 3/4", 1" or 1 1/4" regulator covering the outlet range from 1 psig to 20 psig without downstream control.
3. Where very accurate psi to psi regulation ($\pm 1\%$ outlet pressure absolute) is desired than is obtainable from conventional spring loaded regulators ahead of a "Fixed Factor Billing" Meter or ahead of a "Pressure Compensating Index" Meter.
4. As a reliable and accurate replacement (without downstream control) for conventional regulators requiring downstream control.

CL-231N: For medium size commercial and industrial installations.

1. Metering loads (approximately 500 to 7500 CFH*) without need for expensive instrumentation.
2. As a 1 1/2" or 2" regulator covering the outlet range from 1 psig to 20 psig without downstream control.
3. Where very accurate psi to psi regulation ($\pm 1\%$ outlet pressure absolute) is desired than is obtainable from

conventional spring loaded regulators ahead of a "Fixed Factor Billing" Meter or ahead of a "Pressure Compensating Index" Meter.

4. As a reliable and accurate replacement (without downstream control) for conventional regulators requiring downstream control.

Construction

The construction of the Main Regulator is practically the same as a standard B-31 service regulator, except that the main spring is installed to CLOSE THE VALVE.

The pilot is a simple reducing regulator without internal relief. A separate safety relief valve or other over-pressure protection device is required. (This regulator is sold only as a pilot for CL-31N and CL-231N regulators; not available as a separate regulator). Optional filter available in control line.

Principle of Operation

Same as CL-34 Series Regulators applied to smaller flows.

Specifications

CL-31N Connection Sizes:

Inlet — 3/4", 1", 1 1/4" Scw.

Outlet — 3/4", 1", 1 1/4" Scw.

Note: Inlet and Outlet sizes can be mixed (e.g. Inlet 3/4" with Outlet 1") so long as Outlet is never smaller than Inlet size.

Outlet Pressure: 1 psig to 20 psig

Inlet Pressure per Orifice Size:

1/8", 3/16", 1/4" dia. orifice = 125 psig

3/8" dia. orifice = 60 psig

CL-231N Connection Sizes:

Inlet — 1 1/4", 1 1/2", 2" Scw.

Outlet — 1 1/2", 2" Scw.

Also available — 2" and 3" flanged for Inlet or Outlet

Note: Inlet and Outlet flanged connections cannot be intermixed in CL-231N. Screwed connections can be intermixed so long as Outlet is never smaller than Inlet size.

Loading Ring Settings (CL-231N)

For inlet pressures below 15 psig. 12°

For inlet pressures above 15 psig. 15°

Outlet Pressure: 1 psig to 20 psig

Inlet Pressure per orifice size:

1/4" dia. orifice = 125 psig

3/8" dia. orifice = 75 psig

1/2" dia. orifice = 50 psig

Closing Spring (Non adjustable)

Light Green only.

(Based on 2:1 safety factor of Inlet pressure vs. closing spring power).

*0.6 Sp Gr Gas. 14.7 psia. 60°F

CL-31N CAPACITY TABLE

Inlet Pressure PSIG	Outlet Pressure PSIG	CAPACITY 0.6 Sp. Gr. Gas, SCFH*			
		1/8 Orifice	3/16 Orifice	1/4 Orifice	3/8 Orifice
2	1		300	300	
3	1		400	500	950
	2		325	350	
5	1	325	550	850	1650
	2	275	500	800	1450
10	1	400	825	1450	2550
	2	400	825	1450	2550
	5	400	625	1050	1700
15	1	500	1025	1750	3300
	2	500	1025	1750	3300
	5	500	1025	1700	2750
	10	400	700	1000	1700
20	1	575	1275	2100	3700
	2	575	1275	2100	3700
	5	575	1200	2100	3500
	10	500	1075	1750	3000
	15	400	825	800	1700
30	1	700	1600	2800	4000
	2	700	1600	2800	4000
	5	700	1600	2800	4000
	10	700	1600	2800	4000
	15	700	1450	2100	4000
	20	575	1200	1900	3200
40	1	900	1975	3400	4000
	2	900	1975	3400	4000
	5	900	1975	3400	4000
	10	900	1975	3400	4000
	15	900	1975	3300	4000
	20	900	1850	3300	4000
50	1	1075	2350	4000	4000
	2	1075	2350	4000	4000
	5	1075	2350	4000	4000
	10	1075	2350	4000	4000
	15	1075	2350	4000	4000
	20	1075	2350	4000	4000
60	1	1200	2675	4000	4000
	2	1200	2675	4000	4000
	5	1200	2675	4000	4000
	10	1200	2675	4000	4000
	15	1200	2675	4000	4000
	20	1200	2675	4000	4000
75	1	1400	3150	4000	
	2	1400	3150	4000	
	5	1400	3150	4000	5200
	10	1400	3150	4000	
	15	1400	3150	4000	
	20	1400	3150	4000	
100	1	1700	4000	4000	
	2	1700	4000	4000	
	5	1700	4000	4000	6500
	10	1700	4000	4000	
	15	1700	4000	4000	
	20	1700	4000	4000	
125	1	2100	4000	4000	
	2	2100	4000	4000	
	5	2100	4000	4000	7500
	10	2100	4000	4000	
	15	2100	4000	4000	
	20	2100	4000	4000	

CL-231N CAPACITY TABLE

Inlet Pressure PSIG	Outlet Pressure PSIG	CAPACITY 0.6 Sp. Gr. Gas SCFH*		
		1/4 Orifice	3/8 Orifice	1/2 Orifice
2	1	475	675	1100
3	1	675	1050	1750
	2	475	750	1250
5	1	940	1650	2600
	2	800	1550	2300
10	1	1440	2700	4350
	2	1400	2700	4200
	5	1150	2100	3000
15	1	1850	3550	5950
	2	1850	3550	5950
	5	1750	3200	5200
	10	1100	2100	2950
20	1	2200	4300	7250
	2	2200	4300	7250
	5	2100	4100	6700
	10	1850	3450	5700
	15	1100	1650	2600
30	1	2800	5800	7500 (10000)
	2	2800	5800	7500 (10000)
	5	2800	5800	7500 (9600)
	10	2700	5350	7500 (8600)
	15	2350	4350	7450
	20	2100	3600	6300
40	1	3500	7100	7500 (12000)
	2	3500	7100	7500 (12000)
	5	3500	7100	7500 (12000)
	10	3500	7100	7500 (12000)
	15	3300	6100	7500 (9000)
	20	3200	6000	7500 (9000)
50	1	4100	7500 (8200)	7500 (15000)
	2	4100	7500 (8200)	7500 (15000)
	5	4100	7500 (8200)	7500 (15000)
	10	4100	7500 (8200)	7500 (15000)
	15	4100	7500 (8100)	7500 (13000)
	20	3500	7500 (8000)	7500 (12000)
60	1	4600	7500 (9000)	
	2	4600	7500 (9000)	
	5	4600	7500 (9000)	
	10	4600	7500 (9000)	
	15	4600	7500 (9000)	
	20	4600	7500 (9000)	
75	1	5600	7500 (10500)	
	2	5600	7500 (10500)	
	5	5600	7500 (10500)	
	10	5600	7500 (10500)	
	15	5600	7500 (10500)	
	20	5600	7500 (10500)	
100	1	7100		
	2	7100		
	5	7100		
	10	7100		
	15	7100		
	20	7100		
125	1	7500 (8000)		
	2	7500 (8000)		
	5	7500 (8000)		
	10	7500 (8000)		
	15	7500 (8000)		
	20	7500 (8000)		

Capacity figures shown based on 1% Abs. Drop in Outlet Pressure from set point.

Capacity figures shown in parentheses represent maximum flow rates through the regulator at the indicated pressures. However, the CL-31N is not recommended for flow rates greater than 4000 SCFH 0.6 Sp. Gr. Gas. The CL-231N is not recommended for flow rates greater than 7500 SCFH 0.6 Sp. Gr. Gas.

NOTE: 3/4" NPT Outlet pipe size will limit the capacity to 2000 SCFH on CL-31N.

1" NPT Outlet pipe size will limit the capacity to 3000 SCFH on CL-31N.

SET — Regulator set at indicated inlet and outlet pressure when flowing 100 cfm of 0.6 Sp. Gr. Gas

How to use the curves — sample problems.

Example:

CL-31N, 1/8" Orifice
 Set @ 25 PSIG Inlet Pressure
 5 PSIG Outlet Pressure
 W.O.R., Change Inlet Pressure to 60 PSIG and 15 PSIG

WHAT IS THE CHANGE IN OUTLET PRESSURE IN % ABSOLUTE?

Solution:

1. At set point, differential pressure (ΔP) is: $25 - 5 = 20$ PSIG
2. Go to curve at 20 PSI ΔP , 1/8" orifice, read: ".55." This is the "zero" starting point. Note that the number itself does not mean anything, since we are looking for differences.
3. At 60 PSIG inlet, the ΔP is: $60 - 5 = 55$ PSIG. Go to ΔP 55 and read: ".40."
4. The difference in outlet pressure by changing from 25 PSIG to 60 PSIG is the difference between the two numbers: $.40 - .55 = -.15\%$ ABS.

CL-31N

OUTLET PRESSURE CHANGE AS A RESULT OF INLET PRESSURE CHANGE

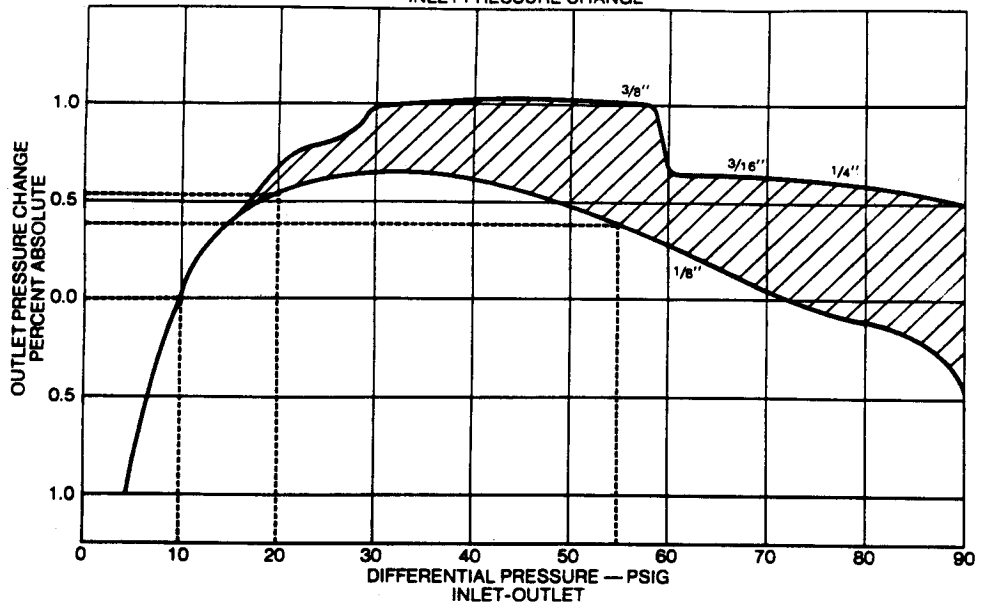

5. At 15 PSIG inlet, the ΔP is: $15 - 5 = 10$ PSIG. Go to ΔP 10 and read: ".00".
6. The difference in outlet pressure by changing from 25 PSIG to 15 PSIG is the difference between the two numbers: $.00 - .55 = -.55\%$ ABS.
7. The total swing in outlet pressure resulting from a 15 PSIG to 60 PSIG inlet pressure is $-.55$ to $-.15\%$ ABS.

Example:

CL-231N, 3/8" orifice
 Set @ 25 PSIG Inlet Pressure
 5 PSIG Outlet Pressure
 W.O.R., Change Inlet Pressure to 60 PSIG and 15 PSIG

WHAT IS THE CHANGE IN OUTLET PRESSURE IN % ABSOLUTE?

Solution:

1. At set point, differential pressure (ΔP) is: $25 - 5 = 20$ PSIG
2. Go to curve at 20 PSIG ΔP , 3/8" orifice, read: ".95" This is the "zero" starting point. The number itself does not mean anything, since we are looking for differences.
3. At 60 PSIG inlet, the ΔP is $60 - 5 = 55$ PSIG. Go to ΔP 55 and read: "1.25."
4. The difference in outlet pressure by changing the inlet pressure from 25 PSIG to 60 PSIG is the difference between the two numbers: $1.25 - .95 = +.30\%$ ABS.
5. At 15 PSIG inlet, the ΔP is: $15 - 5 = 10$ PSIG. Go to ΔP 10 and read: ".00".
6. The difference in outlet pressure by changing from 25 PSIG to 15 PSIG is the difference between the two numbers: $.00 - .95 = -.95\%$ ABS.
7. The total swing in outlet pressure resulting from a 15 PSIG to 60 PSIG inlet pressure is $-.95$ to $+.30\%$ ABS.

CL-231N

OUTLET PRESSURE CHANGE AS A RESULT OF INLET PRESSURE CHANGE

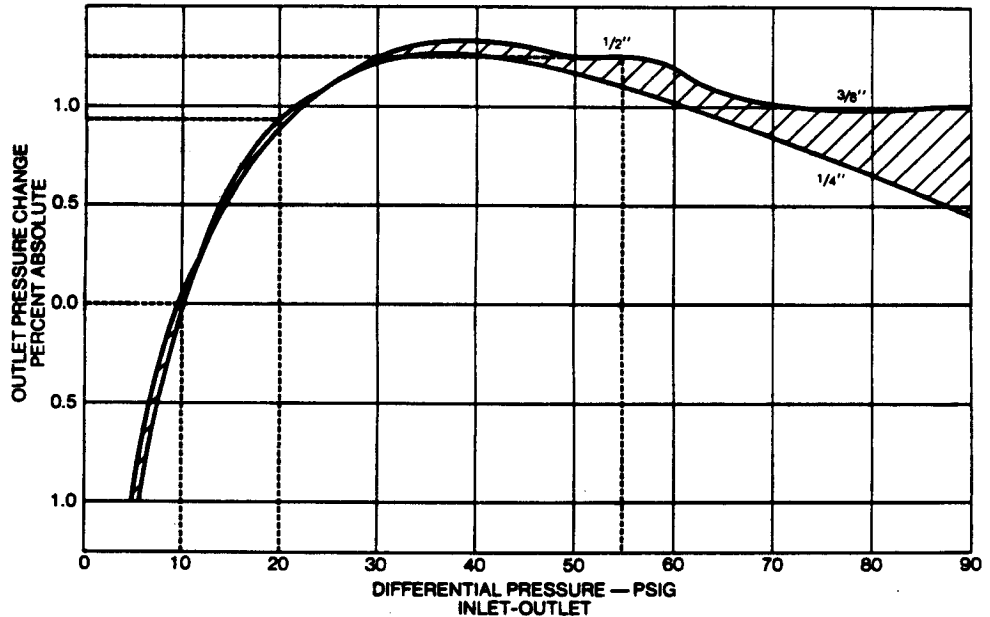

WARRANTY

Schlumberger Industries, Highway 127 North, Owenton, Kentucky 40359, warrants this gas product against defects in materials and workmanship for a period of one year from the date the product was shipped by Schlumberger to the original purchaser. During such one-year period, provided that the original purchaser continues to own the product, Schlumberger will, at its sole option, repair any defects, replace the product or repay the purchase price.

This Warranty will be void if the purchaser fails to observe the procedures for installation, operation or service of the product as set forth in the Operating Manual and Specifications for the product or if the defect is caused by tampering, physical abuse or misuse of the product.

SCHLUMBERGER SPECIFICALLY DISCLAIMS ALL IMPLIED WARRANTIES INCLUDING THOSE OF MERCHANTABILITY OR OF FITNESS FOR A PARTICULAR PURPOSE. UNDER NO CIRCUMSTANCES WILL SCHLUMBERGER BE LIABLE FOR INCIDENTAL OR CONSEQUENTIAL DAMAGES OF ANY KIND WHATSOEVER.

In the event of a malfunction of the product, consult your Schlumberger Service Representative or Schlumberger Industries, Highway 127 North, Owenton, Kentucky 40359.

Schlumberger Industries

Gas Division

Gas Division, 970 Highway 127 North, Owenton, Kentucky 40359-9302
 Phone: (502) 484-5747, FAX: (502) 484-5840, Customer Service: (502) 484-5741

Constant Loaded Regulators

CL-31
CL-231

ASSEMBLY POSITIONS

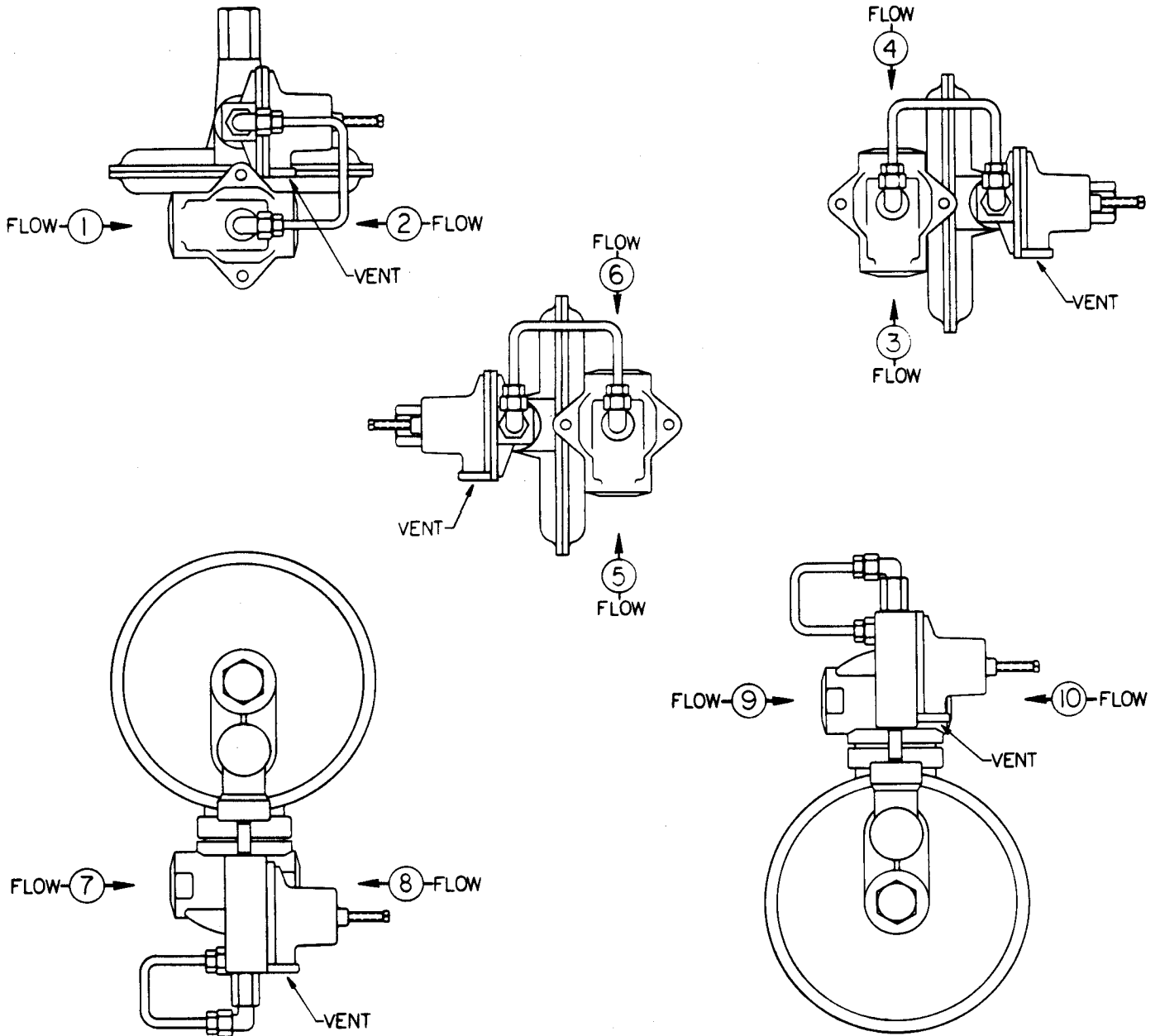

Schlumberger Industries

Gas Division

Gas Division, 970 Highway 127 North, Owenton, Kentucky 40359-9302
Phone: (502) 484-5747, FAX: (502) 484-5840, Customer Service: (502) 484-5741
Measurement Division, 7275 West Credit Avenue, Mississauga, Ontario L5N 5M9
Phone: (416) 858-4211, FAX: (416) 858-0428